

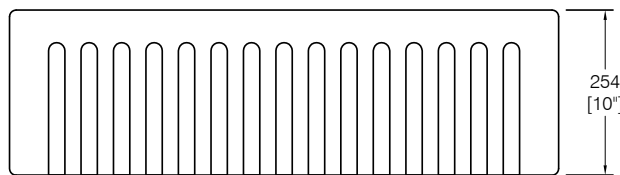

DSE-FCA5050S

UPC: 813649021295

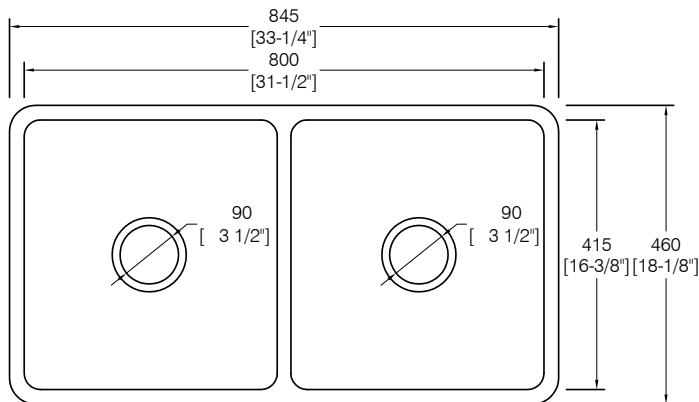

A Surface

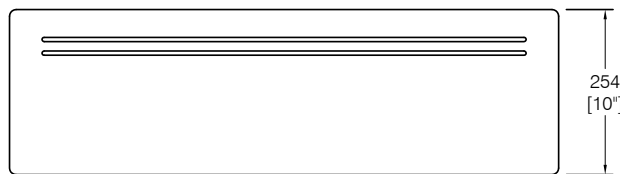

B Surface

Style:

- Reversible Apron Front
- Kitchen Sink
- 50/50 Double Bowl

Material:

- Fire Clay

Size:

- Overall: 33.25"x18.125"x10"

Features:

- 2 Apron Styles
- Apron 1: Double Pin-Striped
- Apron 2: Scalloped

Certifications:

- cUPC

Warranty:

- Lifetime Limited Warranty



Available Color/Finish



White